

RED HAT  
**SUMMIT**

# RED HAT DEVELOPER TOOLSET:

Build, Run, & Analyze Applications On  
Multiple Versions of Red Hat Enterprise Linux

Dr. Matt Newsome  
Engineering Manager – Tools  
13/JUN/13



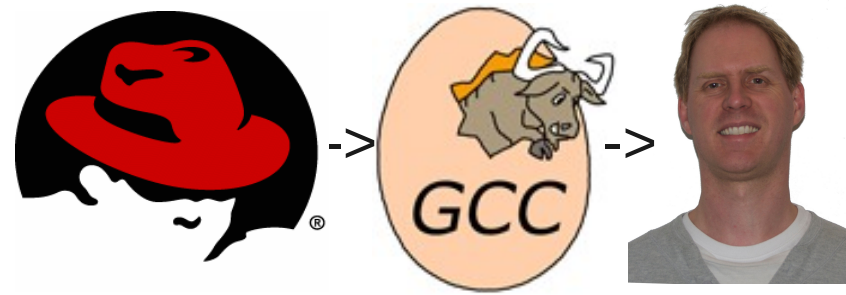

# Introduction

- Dr. Matt Newsome  
Engineering Manager, Toolchain team
  - Responsible for toolchains in Fedora and RHEL
  - Toolchain:
    - GCC compiler suite
    - Language-specific runtimes
    - binutils assembler/linker/etc
    - OpenMP
    - Ancillary tools
  - Development lead for Red Hat Developer Toolset

# Overview

- Red Hat Enterprise Linux Tools
  - Available Tools and Status
  - Work-in-progress
- Developer Toolset
  - Background:
    - Why did we make Developer Toolset?
    - What is in Developer Toolset?
    - Lifecycle and Roadmap
    - How to get and use Developer Toolset
    - What's new in Developer Toolset?
- Common Questions and Answers
- Questions

\* Dates and features may change

RED HAT  
**SUMMIT**

# Red Hat Enterprise Linux Tools

# Toolchain Support

Production 1 (approx. 5 1/2 years)					Production 2 (approx. 1 year)	Production 3 (approx. 3 1/2 years)				Extended Life Phase (approx. 3 years)		
Year 1	Year 2	Year 3	Year 4	Year 5	Year 6	Year 7	Year 8	Year 9	Year 10	Year 11	Year 12	Year 13

\* The life cycle time spans and dates are subject to adjustment.

- Current Toolchains:
  - RHEL5: gcc-4.1 (2006), gcc-4.4 (2009)
  - RHEL6: gcc-4.4 (2009)
- 10 year RHEL lifecycle
  - High Stability
  - Very limited access to newer GCC releases & features
- *...but our customers also want newer tools on older RHEL*

RED HAT  
**SUMMIT**

# Red Hat Developer Toolset

# High-Level Summary

- What is it?
  - An extra set of up-to-date developer tools
    - Compiler, IDE, debugger, performance analysis tools, etc.
  - Tools run on RHEL x and RHEL x+1
  - Apps developed on RHEL x will work on RHEL x and x+1
- How do I get it?
  - Through Red Hat Developer Subscriptions
  - Through Partner Programs
- When is it available?
  - v1.1 – general availability now
  - v2.0 – Beta released, aiming for GA release this fall

# What is the Developer Toolset?

- More recent developer tools than those shipped in RHEL
- Does not replace RHEL system tools
- 2.0 is the second major Red Hat Developer Toolset release
  - C, C++ and Fortran
  - x86/x86\_64 only
  - Built on Software Collections (more later)
  - Can be installed in parallel with Red Hat Developer Toolset v1.1 and base RHEL tools [i.e. gcc you get in RHEL Server install]

# Why Offer a Developer Toolset?

- Single most common request from customers, partners and ISVs
- More options for developers
  - Build and run on supported RHEL x and RHEL x+1
  - e.g. build on RHEL 5, execute on RHEL 5 and 6
  - Lower development cost (one compiler version)
  - Lower QA cost
    - Build once
    - Test and deploy that one version on multiple RHEL releases

# Building with base RHEL toolchain (1)

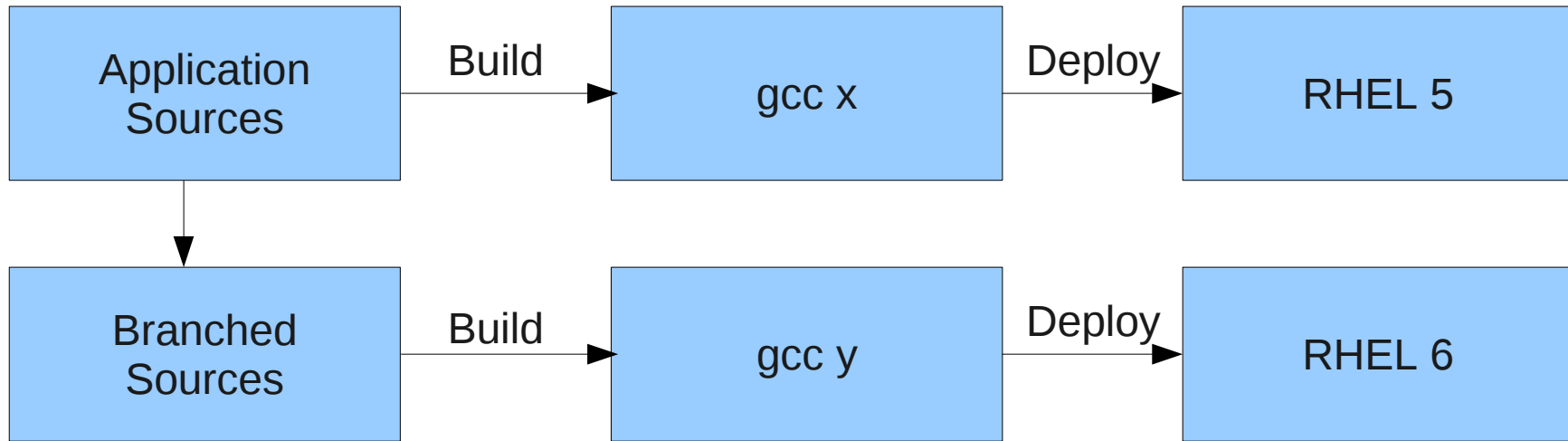

- RHEL system toolchain
  - Multiple versions of gcc
  - Varying features
  - Different source branches for different gcc versions

# Building with base RHEL toolchain (2)

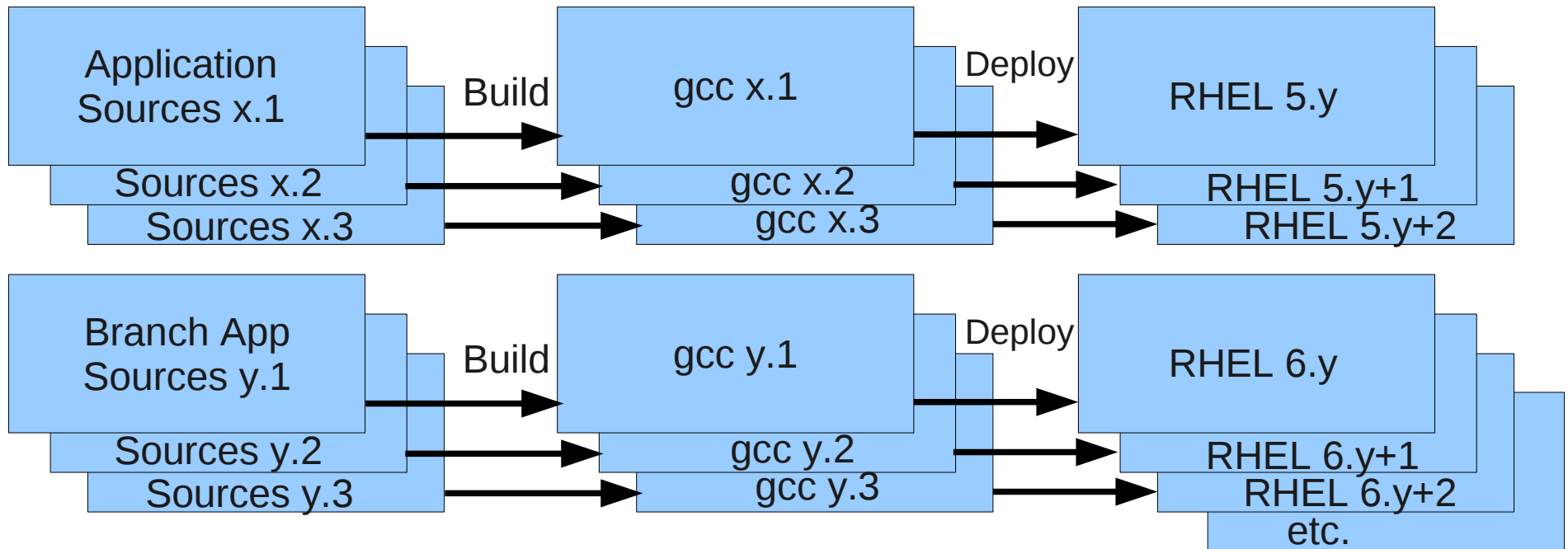

- RHEL system toolchain

- Issues compounded by multiple simultaneous minor releases
- gcc on supported minor releases kept in sync periodically
- But developers may prioritize minor versions differently
- Result: higher development and testing costs

# Developer Toolset Alternative

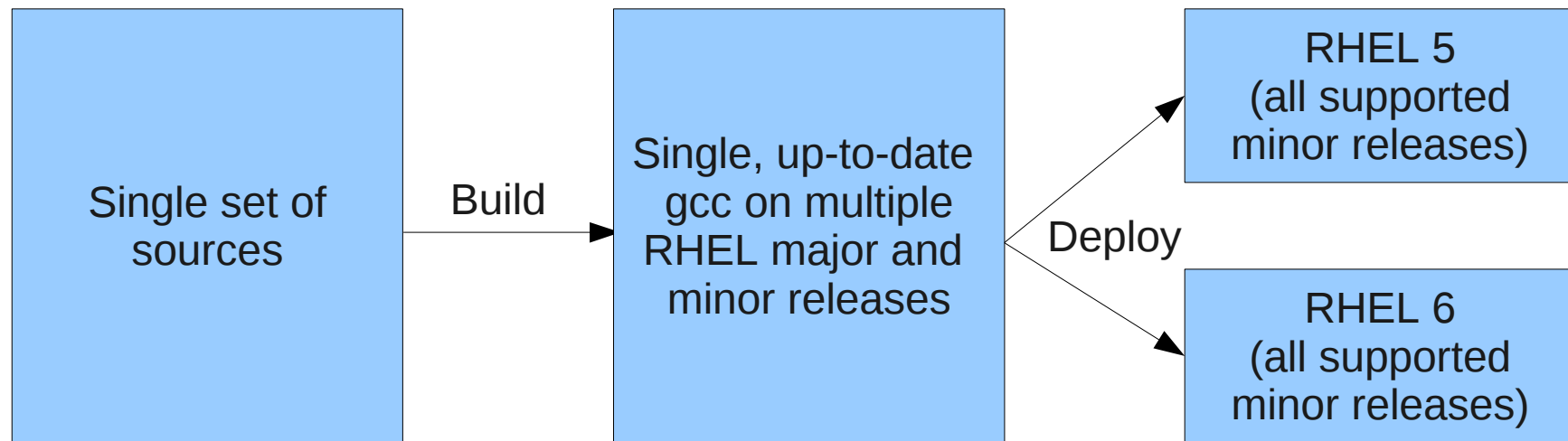

- **Developer Toolset gcc**

- Single version of gcc on all supported RHEL5, RHEL6
- Feature parity, all at the same patch level
- Can deploy application binaries built with the same tools to multiple supported major and minor RHEL releases
- No need to deploy extra libraries with your binaries to support this
- Result: reduced development and testing costs

# What's in Developer Toolset v1.1?

- v1.1 [released]
  - **gcc-4.7**: C, C++ and Fortran Compilers & Associated Runtimes
  - **gdb-7.4**: C, C++ and Fortran debugging
  - **binutils-2.22**: x86/x86\_64 assembler, linker, etc.
  - **Software Collection .rpm's** for RHEL6 and RHEL5
  - All components released in Fedora 18, planned for future RHEL
  - Can be used with Eclipse in base RHEL x86/x86\_64

# What's in Developer Toolset v1.1? [continued]

- v1.1 [released]
  - **SystemTap-1.8**: diagnostic tool for live analysis, programmable on-line response, and whole-system symbolic access
  - **Valgrind-3.8.0**: profiling programs and detecting memory management and threading errors
  - **OProfile-0.9.7**: low overhead system wide profiler for systems of all sizes
  - **elfutils-0.154**: provides a library and utilities to access, modify and analyze ELF objects
  - **dwz-0.7**: new tool to compress DWARF debug into smaller debuginfo files

# What's updated in Developer Toolset 2.0?

- v2.0 [Beta: May; GA: aiming for Fall 2013]
- Contains the following rebased components:
  - **gcc-4.8** [rebased to 2013 release]
  - **gdb-7.6** [rebased, corresponds to gcc-4.8]
  - **SystemTap 2.1** [rebased]
  - **Valgrind 3.8.1** [rebased]
  - **Elfutils 0.155** [rebased]
  - **OProfile 0.9.8** [rebased]
  - **dwz 0.1** [rebased, DWARF optimizer & duplicate removal utility]

# What's new in Developer Toolset 2.0?

- v2.0 [Beta: May; GA: aiming for Fall 2013]
- Provides the following new components for developers:
  - **Eclipse IDE 4.3** provides the 2013 “Kepler” Eclipse Foundation community release of this powerful Integrated Development Environment [RHEL6 only]
  - **dyninst 8.0** delivers a powerful application program interface (API) that aids the development of performance measurement tools, debuggers, and simulators by permitting the insertion of code into a running program
  - **strace 4.7** traces system calls, helping developers more efficiently debug programs and identify the root cause of crashes or other unexpected behavior
  - **memstomp** helps identify code which relies on undefined behavior at a lower runtime cost than other tools such as Valgrind

# Updated GNU Compiler Collection (GCC) 4.8

Significant enhancements to GCC 4.8 include:

- **Local Register Allocator (LRA)**
  - New register allocator contributed by Red Hat
  - x86/x86-64 generated code quality improvements
- **C++11**
  - Support for the latest C++ standard
- Ability to compile extremely large functions with smaller memory consumption in less time
- Support for Hardware Transactional Memory on upcoming Intel CPU architectures

# Eclipse Integrated Development Environment (“Kepler”) [RHEL6 x86/x86\_64 only]

The screenshot displays the Eclipse IDE Kepler interface. The top menu bar includes File, Edit, Source, Refactor, Navigate, Search, Project, Run, Window, and Help. The toolbar contains various icons for file operations and development. The Project Explorer on the left shows a project named 'cpp11demo' with a source folder containing 'algorithm', 'iostream', 'thread', 'unistd.h', 'vector', and 'std'. The main editor window shows the source code for 'cpp11demo.cpp', which is a C++ program using threads. The code includes headers for <math>\langle\mathbf{thread}\rangle</math>, <math>\langle\mathbf{vector}\rangle</math>, <math>\langle\mathbf{algorithm}\rangle</math>, and <math>\langle\mathbf{unistd.h}\rangle</math>. The main function initializes a vector of threads, each performing a task with a random delay. The program outputs 'Hello Developer Toolset' and 'EXECUTION COMPLETE'. The Outline view on the right shows the project's structure, including the 'main()' function. The Console view at the bottom is empty, displaying 'No consoles to display at this time.' The status bar at the bottom shows the current file path: '/cpp11demo/src/cpp11demo.cpp - [main]'. A watermark for 'eclipse KEPLER' is overlaid on the right side of the image.

```
std::cout << "hread output" << endl << flush;
}

int main() {
    srand(time(NULL));
    std::vector<std::thread> workers;

    for (int i=1; i < 20; i++) {
        // C++11 threads
        workers.push_back(std::thread([]() {
            // C++11 lambda function
            int randomNumber = rand() % 20;
            if (randomNumber == 15) {
                // randomly introduce a delay in the occasional thread
                std::cout << "Delay..." << endl << flush;;
                sleep(12);
            }
            std::cout << randomNumber << endl << flush;;
            std::cout << "Thread executing" << endl << flush;
        }));
    }
    std::cout << "Hello Developer Toolset\n";
    std::for_each(workers.begin(), workers.end(), [](std::thread& th) {
        th.join();
    });
    cout << "EXECUTION COMPLETE" << endl << flush;;
}
```

# Developer Toolset Life Cycle

- Separate product from RHEL – independent release cycle
- Major release once per year
  - New gcc release in Spring
  - Fedora Release of gcc and other tools in Summer
  - Developer Toolset release follows this
- Support current and one previous major version [e.g. 2.0 + 1.1]
  - Effectively 2 years of support
- Minor release after 6 months
  - Upstream patches; possibly new components
- Z-stream releases for security fixes and serious bugs
  - As in RHEL Production Phase 2

RED HAT  
**SUMMIT**

# Software Collections

# RHEL Software Collections

- What are Software Collections?
  - Structural definition for an application or toolset that is independent of the OS
  - Installed outside the normal hierarchy for RHEL native components (but still compliant with FHS)
- Installs additional applications
  - `/opt/<vendor>/...`
  - Allows multiple versions to be co-installed
  - Each major app version gets a different file system root
  - `scl` script used to activate (`PATH`, `LDCONFIG`, etc.)
- Application lifecycles are independent of RHEL

# Developer Toolset is a Software Collection

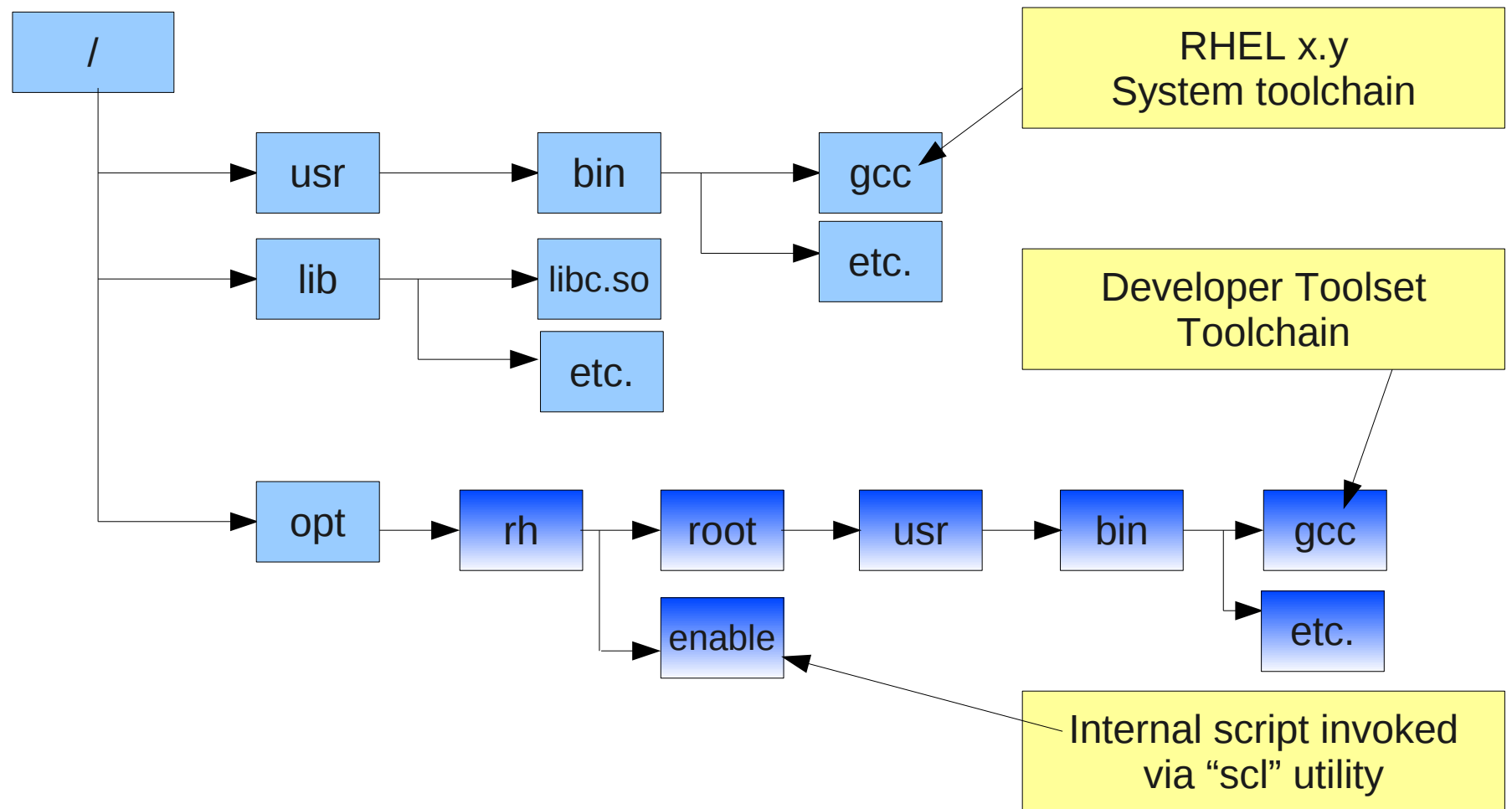

- Separate tools, not default
- Only enabled by deliberate invocation (more later)

RED HAT  
**SUMMIT**

# Practicalities

# Usage

- Subscribe to channel and Install
  - Subscribe to channel using RHN website or command line
    - e.g. `rhn-channel --add --channel=rhel-x86_64-workstation-dts-6`
  - `yum install devtoolset-2`

- Simple usage

```
scl enable devtoolset-2 'gcc -g helloworld.c -o helloworld'
```

```
scl enable devtoolset-2 'gdb helloworld'
```

- More advanced usage

```
scl enable devtoolset-2 'bash'
```

(gcc/gdb/etc. now use toolset versions, not RHEL defaults)

- Eclipse

```
scl enable devtoolset-2 'eclipse'
```

(launches Toolset Eclipse with Toolset gcc/gdb for build/debug)

RED HAT  
**SUMMIT**

# Demonstration

RED HAT  
**SUMMIT**

# Under the Hood

# How does it work?

- Toolset rpm includes `/opt/rh/devtoolset-2/enable`
- Script simply prefixes `PATH`:
  - `/opt/rh/devtoolset-2/root/usr/bin:$PATH`
  - (and adds some environment variables)
- Alternatives
  - `/opt/rh/etc/alternatives/...`

# Linkage

- Most libraries linked dynamically for you from base RHEL
  - All of C Library (glibc - libm, libc, etc)
  - All of OpenMP (libgomp)
  - Most of libstdc++
  - Most of libgcc
- What about newer features? C++11 library contents?
  - Newer features in gcc-4.8 than in gcc-4.1/4.4 in RHEL5/6
  - These parts statically linked for you into your application
- But statically linked code == bad!
  - True, let's dig deeper...

RED HAT  
**SUMMIT**

**Security**

# Security Implications (1)

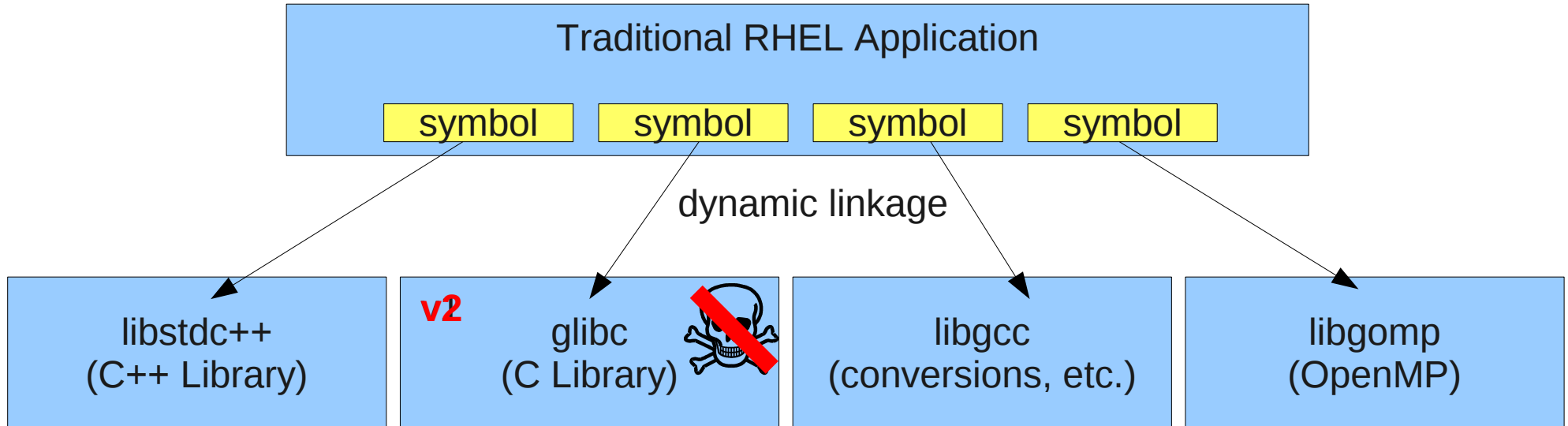

- RHEL Toolchain
  - Dynamic linkage
  - Security updates and bugfixes resolved by normal errata

# Security Implications (2)

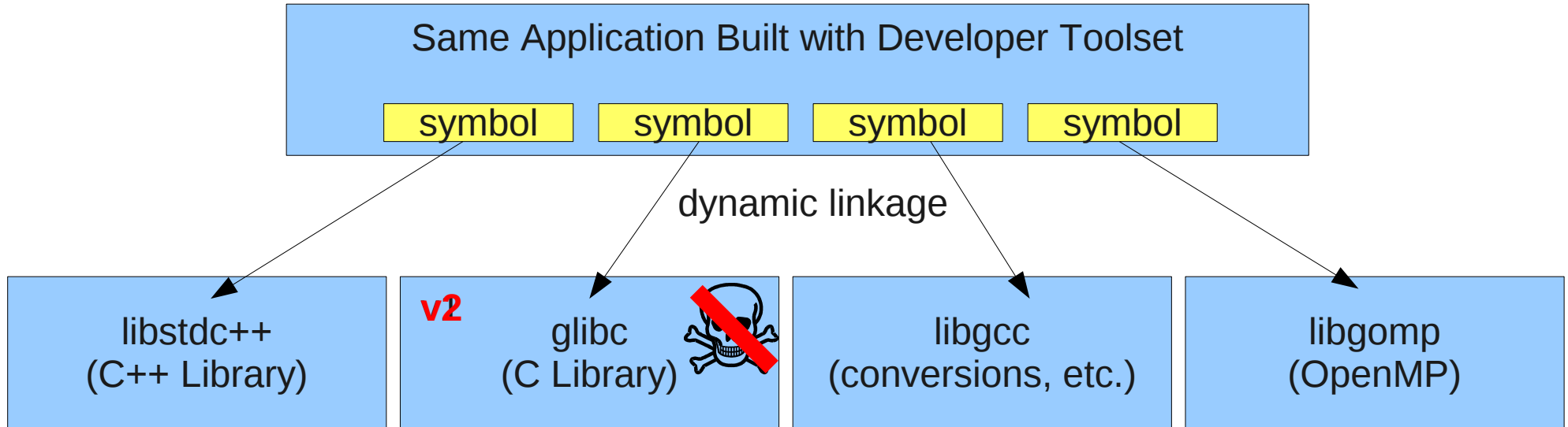

- Developer Toolset Works Similarly
  - Dynamic linkage for most symbols
  - Security updates and bugfixes resolved by normal errata
  - But...

# Security Implications (3)

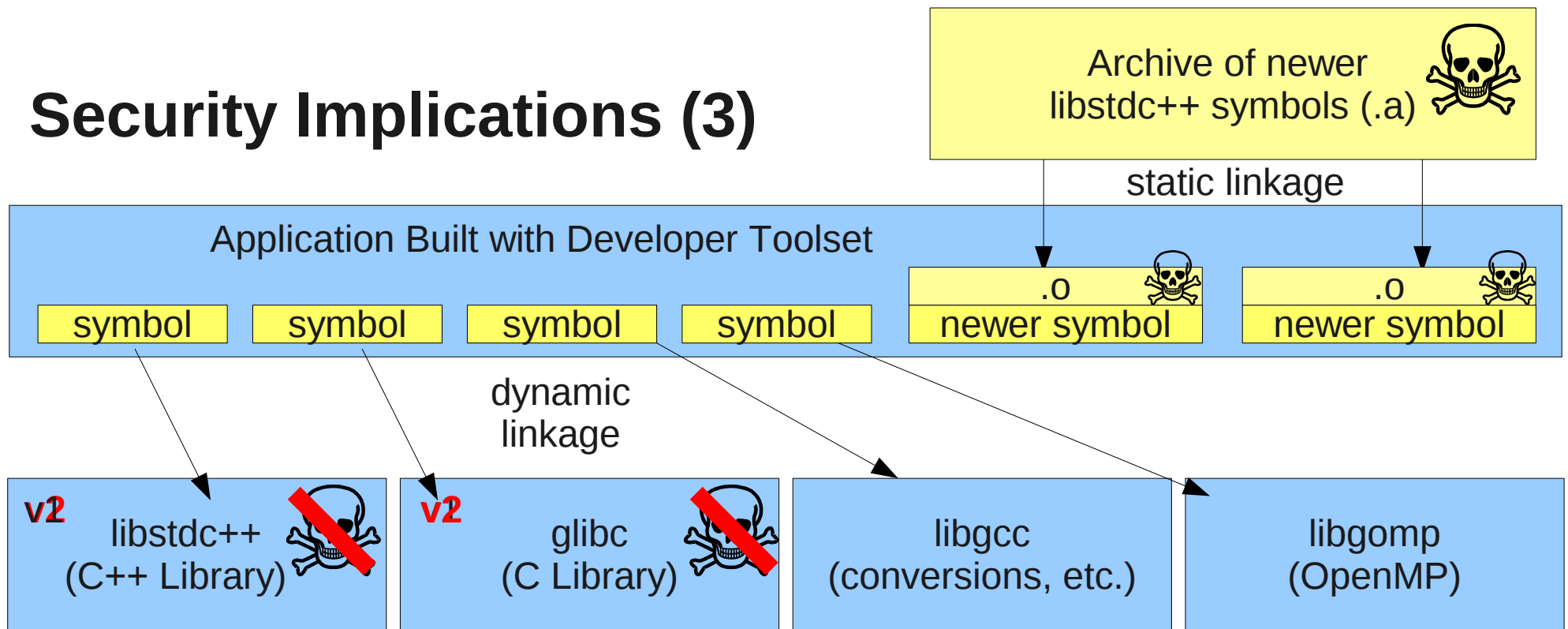

- Developer Toolset Statically Links Newer Symbols
  - Dynamic linkage for most symbols
  - Static linkage for symbols newer than base RHEL libraries
  - Carried in application to avoid carrying extra libraries

# Security Implications (4)

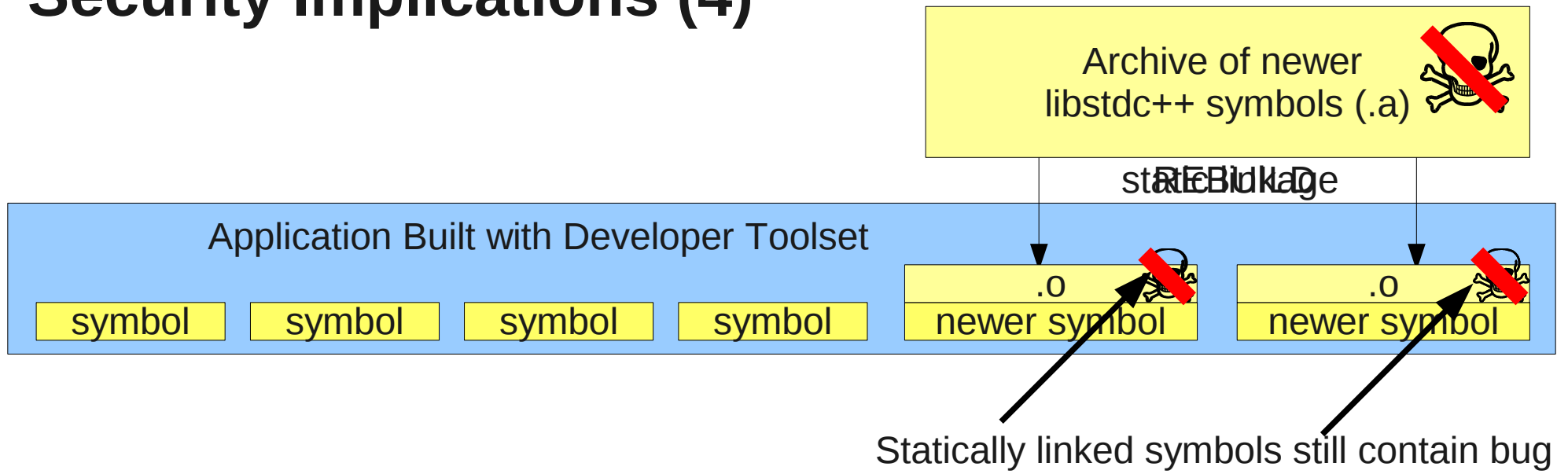

- Developer Toolset Statically Links Newer Symbols
  - Bugs in statically linked objects require rebuild to resolve
  - But...
    - Risk is very low
    - Security errata will inform you if you need to rebuild

RED HAT  
**SUMMIT**

# Common Questions



# Common Questions (1)

- How do I make Developer Toolset gcc/gdb the default?  
scl enable devtoolset-2 'bash' (with caution)
- Will my apps run on future RHEL major releases?
  - If you build today on RHEL6, we expect that application to run without issue on the next major RHEL release
  - But too early – we will test in due course
- How do I use Developer Toolset gcc to...X?
  - scl enable devtoolset-2 '<X>' solves most of these
  - Should be easy to integrate into build systems

## Common Questions (2)

- Which RHEL versions can I run toolset on?
- Which RHEL versions can I run toolset-built apps on?

		<i>"Run on"</i>									
		< 5.9	5.9	5.10	5.11	6.0 EUS	6.1 EUS	6.2 EUS	6.3 EUS	6.4	6.5
<i>"Built with"</i>	< 5.9	Unsupported version of Red Hat Enterprise Linux host									
	5.9	✗	✓	✓	✓	✗	✗	✓	✓	✓	✓
	5.10	✗	✗	✓	✓	✗	✗	✓	✓	✓	✓
	5.11	✗	✗	✗	✓	✗	✗	✓	✓	✓	✓
	6.0 EUS	Unsupported version of Red Hat Enterprise Linux host									
	6.1 EUS	Unsupported version of Red Hat Enterprise Linux host									
	6.2 EUS	✗	✗	✗	✗	✗	✗	✓	✓	✓	✓
	6.3 EUS	✗	✗	✗	✗	✗	✗	✗	✓	✓	✓
	6.4	✗	✗	✗	✗	✗	✗	✗	✗	✓	✓
	6.5	✗	✗	✗	✗	✗	✗	✗	✗	✗	✓

 Unsupported  
 Supported

[Unreleased versions, features and dates are not committed, subject to change]

# Common Questions (3)

- What do gcc-4.7, etc give me as a developer?
  - User guide summarizes main new features
  - Includes fine details on changes from RHEL5/6 equivalent tools
- **Headline Features**
  - **C++11 Language Standard**
    - Leading compiler implementation
    - Atomic extensions for guaranteed atomic access to memory
    - Memory model for clearer semantics
  - **Transactional Memory**
    - Software implementation in gcc-4.7
    - Support for Intel Hardware TM extensions in gcc-4.8
  - **OpenMP v3.1**

# Common Questions (4)

- Gotchas and issues?
  - Release notes spell these out
- Main ones to be aware of
  - C++11, TM are experimental, use with caution or use C++98
  - Some base RHEL errata are required for all features
  - Forwards only (don't build on RHEL6 and run on RHEL5)
  - Forwards only (don't build on rhel-5.8 and run on rhel-5.6)
  - Intended for userland development, not kernel rebuilding

# Common Questions (5)

- How can I download Red Hat Developer Toolset?
  - Good question...

RED HAT  
**SUMMIT**

# Accessing Red Hat Developer Toolset

# How do I get the Developer Toolset?

- Developer Toolset
  - Red Hat Developer Toolset 1.1 GA available today
  - Red Hat Developer Toolset 2.0 Beta available today
- Existing Red Hat Enterprise Linux Subscribers:
  - You may procure a Red Hat Developer Workstation, priced the same as a RHEL Workstation. Contact your sales rep to purchase or convert an exiting subscription.
  - You can also access the Red Hat Developer Toolset 2.0 Beta
- If you are not a RHEL subscriber, you may procure:
  - Red Hat Developer Workstation
  - Red Hat Developer Subscriptions
  - Red Hat Developer Suite
  - Red Hat Not-for-Resale (NFR) Partner Subscription

# Developer Suite

- RHEL Server
  - Up to 8 sockets
  - Unlimited virtual guests
- Features
  - High availability
  - Load balancer
  - Resilient storage
  - Scalable filesystems
  - High-performance networking
  - Extended User Support
- Developer Toolset
- Smart Management
- MRG Real-time

# Access to Developer Toolset

	Developer Suite	Developer Workstation		Developer Support Subscription	
	\$99	Professional	Enterprise	Professional	Enterprise
RHEL	1	1 x Developer Suite		25 x Developer Suite	
Support	Self Support	Unlimited Developer Support by Web and Phone			
Developer Toolset	Included				

Details for Developer Support can be found here: [access.redhat.com/support/offerings/developer/soc.html](https://access.redhat.com/support/offerings/developer/soc.html)

# Subscribing to the Developer Toolset Channel (1)

- Subscribing to a RHEL Channel  
<https://access.redhat.com/knowledge/solutions/11312>
- Access RHN Channels

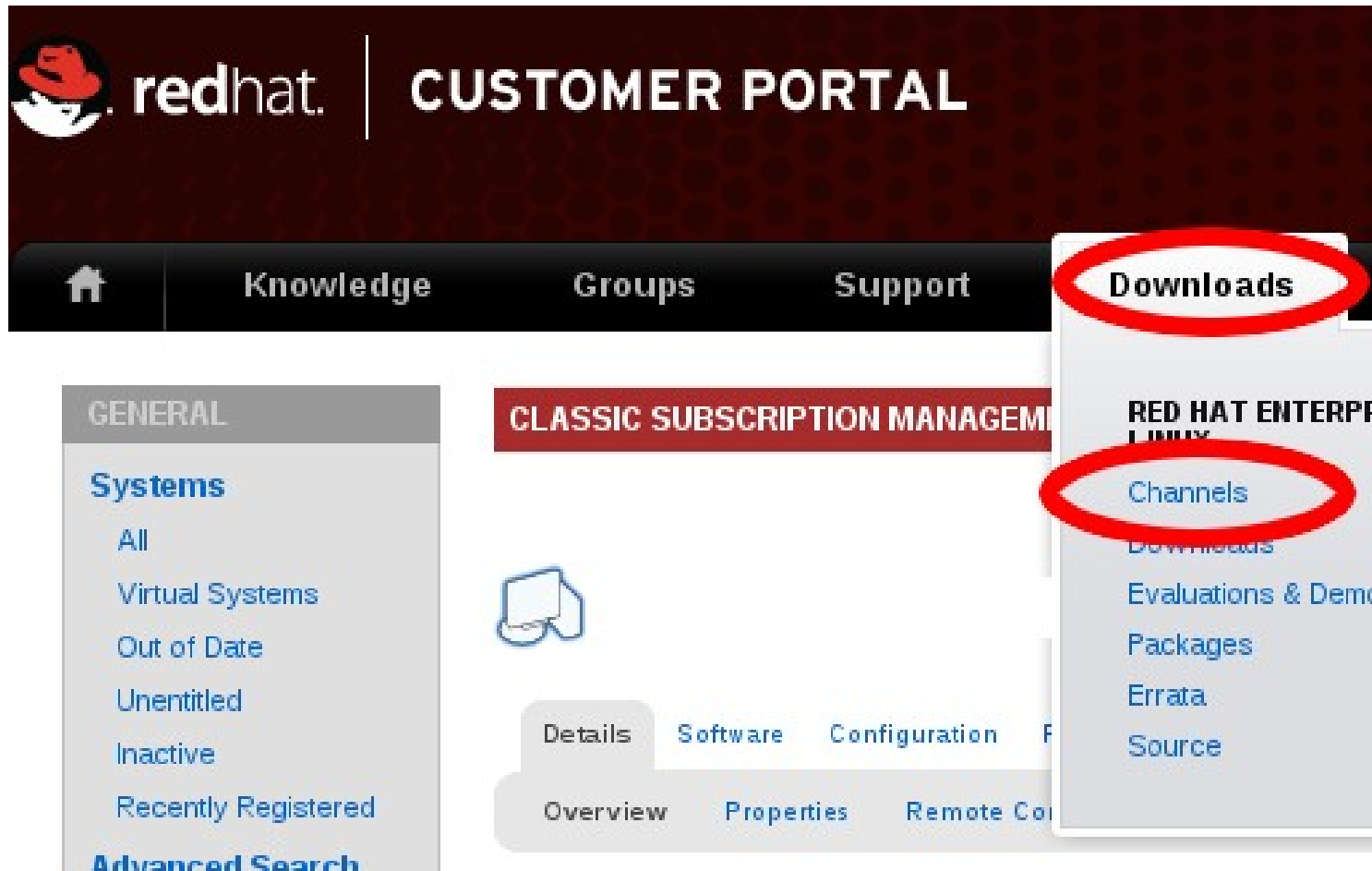

The screenshot displays the Red Hat Customer Portal interface. At the top left is the Red Hat logo and the text "redhat. | CUSTOMER PORTAL". Below this is a navigation bar with links for "Home", "Knowledge", "Groups", and "Support". A "Downloads" link is highlighted with a red circle. A dropdown menu is open from the "Downloads" link, showing options: "Channels" (highlighted with a red circle), "Downloads", "Evaluations & Demos", "Packages", "Errata", and "Source". On the left side, there is a "GENERAL" sidebar with links for "Systems", "All", "Virtual Systems", "Out of Date", "Untitled", "Inactive", "Recently Registered", and "Advanced Search". The main content area shows "CLASSIC SUBSCRIPTION MANAGEMENT" with a hand icon and tabs for "Details", "Software", "Configuration", "Overview", "Properties", and "Remote Co".

# Subscribing to the Developer Toolset Channel (2)

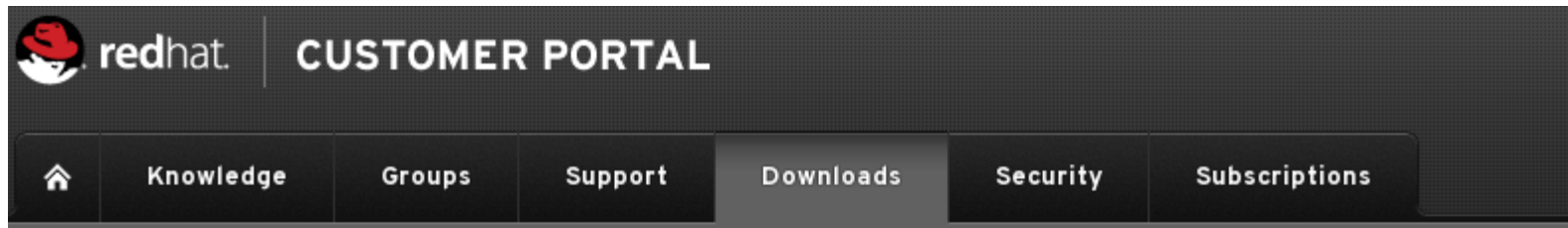

## Full Software Channel List

[All Release Channels](#) [All Beta channels](#) [Retired channels](#)

Channels provide you with a way to keep your software and systems up to date.

The software channels accessible from this page are all of the channels to which your organization is entitled. Information on how these [production support policies](#) and [product update policies](#).

Alternatively, you may also view a list of [retired channels](#) or a list of [Beta channels](#).



You can also **download ISO images** of channel content on the [Download Software](#) page.

Filter by Product Channel:

Channel Name	Architecture
<input type="checkbox"/> Red Hat Enterprise Linux Server 6	<a href="#">IA-32, IA-32, PF</a>
<input type="checkbox"/> Red Hat Common Server 6	<a href="#">IA-32, IA-32, PF</a>
<input type="checkbox"/> Red Hat Common Server 6	<a href="#">IA-32, IA-32, PF</a>
<input type="checkbox"/> Red Hat Developer Toolset Server 6	<a href="#">IA-32, x86_64</a>

# Subscribing to the Developer Toolset Channel (3)

- Subscribe Target Systems

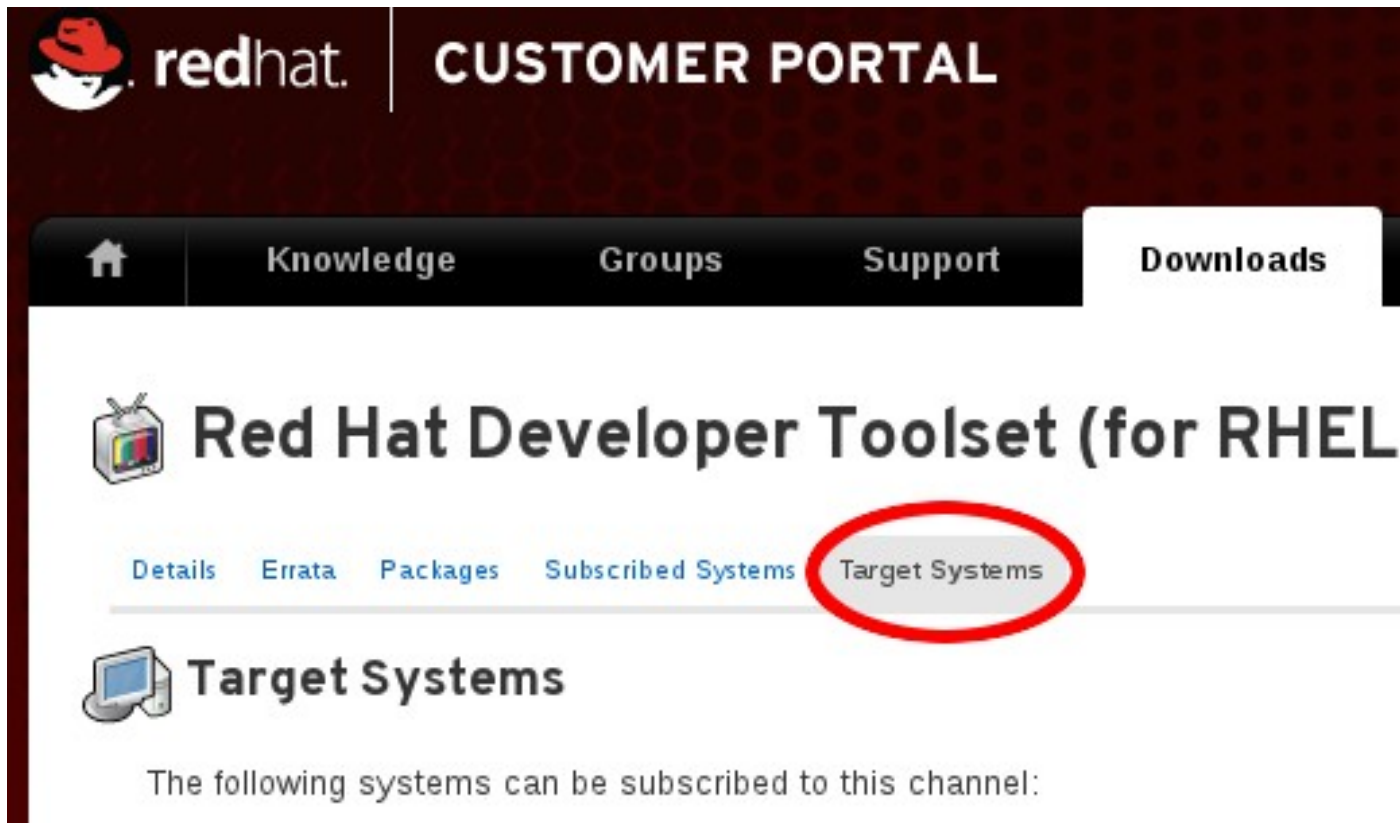

The screenshot shows the Red Hat Customer Portal interface. At the top left is the Red Hat logo and the text "redhat." followed by "CUSTOMER PORTAL". Below this is a navigation bar with links for "Knowledge", "Groups", "Support", and "Downloads". The main content area features a large heading "Red Hat Developer Toolset (for RHEL)" with a television icon. Below the heading are several tabs: "Details", "Errata", "Packages", "Subscribed Systems", and "Target Systems". The "Target Systems" tab is highlighted with a red circle. Below the tabs is a section titled "Target Systems" with a computer icon and the text "The following systems can be subscribed to this channel:".

# Command Line Access to Developer Toolset v1.1

- Subscribe to channel (typical example with RHEL6 x86\_64):

- RHN Classic

```
rhn-channel --available-channels  
rhn-channel --add --channel=rhel-x86_64-server-dts-6  
rhn-channel --list (to verify channel addition)
```

- Red Hat Subscription Management

```
subscription-manager list --available  
subscription-manager subscribe --pool=<pool_id>  
subscription-manager list --consumed (verify subscription attached)  
yum-config-manager --enable rhel-server-dts-6-rpms
```

- Install

- yum install devtoolset-1.1

- See User Guide for full details:

- <http://red.ht/devToolset>

# Cmd Line Access to Developer Toolset v2.0 Beta

- Subscribe to channel (typical example with RHEL6 x86\_64):

- RHN Classic

```
rhn-channel --available-channels
rhn-channel --add -channel=rhel-x86_64-server-optional-6 (required)
rhn-channel --add -channel=rhel-x86_64-server-dts2-6-beta
rhn-channel --list (to verify channel addition)
```

- Red Hat Subscription Management

```
subscription-manager list --available
subscription-manager subscribe --pool=<pool_id>
subscription-manager list --consumed (verify subscription attached)
yum-config-manager --enable rhel-server-optional-6-rpms (required)
yum-config-manager --enable rhel-server-dts2-6-beta-rpms
```

- Install

- `yum install devtoolset-1.1`

- See User Guide for full details:

- <http://red.ht/devToolset>

# Developer Toolset Workflow

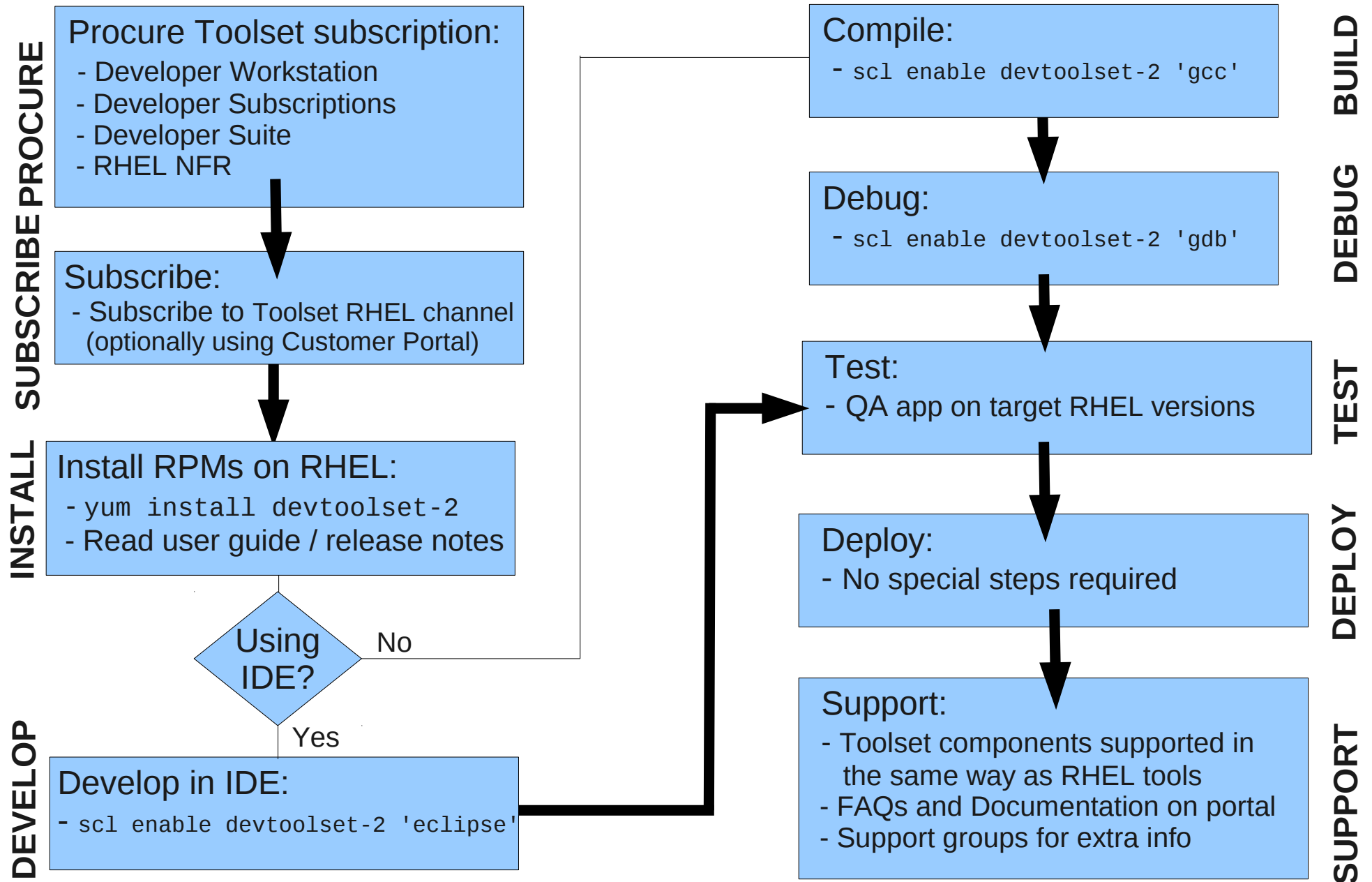

# Links

- Resources
  - Developer Program (“Developer Connection”)
    - <http://red.ht/rheldevelop>
  - Developer Toolset Docs
    - <http://red.ht/devToolset>

# Links for Developer Toolset v1.1

- ***Main Link: Red Hat Developer Toolset 1.1 User Guide***

[Link](#)

- Red Hat Developer Toolset 1.1 Release Notes

[Link](#)

- Red Hat Software Collections Guide

[Link](#)

- Red Hat Enterprise Linux 6

- Developer Guide

[https://docs.redhat.com/docs/en-US/Red\\_Hat\\_Enterprise\\_Linux/6/html/Developer\\_Guide/index.html](https://docs.redhat.com/docs/en-US/Red_Hat_Enterprise_Linux/6/html/Developer_Guide/index.html)

- Installation Guide

[https://docs.redhat.com/docs/en-US/Red\\_Hat\\_Enterprise\\_Linux/6/html/Installation\\_Guide/index.html](https://docs.redhat.com/docs/en-US/Red_Hat_Enterprise_Linux/6/html/Installation_Guide/index.html)

- Deployment Guide

[https://docs.redhat.com/docs/en-US/Red\\_Hat\\_Enterprise\\_Linux/6/html/Deployment\\_Guide/index.html](https://docs.redhat.com/docs/en-US/Red_Hat_Enterprise_Linux/6/html/Deployment_Guide/index.html)

- Support

[https://docs.redhat.com/docs/en-US/Red\\_Hat\\_Developer\\_Toolset/...](https://docs.redhat.com/docs/en-US/Red_Hat_Developer_Toolset/...)

# Links for Developer Toolset v2.0 Beta

- ***Main Link: Red Hat Developer Toolset 2.0 Beta User Guide***

[Link](#)

- Red Hat Developer Toolset 2.0 Beta Release Notes

[Link](#)

- Red Hat Software Collections Guide

[Link](#)

- Red Hat Enterprise Linux 6

- Developer Guide

[https://docs.redhat.com/docs/en-US/Red\\_Hat\\_Enterprise\\_Linux/6/html/Developer\\_Guide/index.html](https://docs.redhat.com/docs/en-US/Red_Hat_Enterprise_Linux/6/html/Developer_Guide/index.html)

- Installation Guide

[https://docs.redhat.com/docs/en-US/Red\\_Hat\\_Enterprise\\_Linux/6/html/Installation\\_Guide/index.html](https://docs.redhat.com/docs/en-US/Red_Hat_Enterprise_Linux/6/html/Installation_Guide/index.html)

- Deployment Guide

[https://docs.redhat.com/docs/en-US/Red\\_Hat\\_Enterprise\\_Linux/6/html/Deployment\\_Guide/index.html](https://docs.redhat.com/docs/en-US/Red_Hat_Enterprise_Linux/6/html/Deployment_Guide/index.html)

- Support

[https://docs.redhat.com/docs/en-US/Red\\_Hat\\_Developer\\_Toolset/...](https://docs.redhat.com/docs/en-US/Red_Hat_Developer_Toolset/...)

RED HAT  
**SUMMIT**

Questions

# References

- Related Talks / Demos:
  - Developer Day:
    - Tools for RHEL Developers – up next (this track, 10:30am)
    - Alternatively, Software Collections talk in track 3 (10:30am)
    - Diagnosing Performance Problems (this track, 12:30pm)
    - Profiling C++ Applications with Eclipse (this track, 1:30pm)
    - Debugging with GDB (this track, 2:30pm)
  - Summit
    - Repeat of this talk at Summit (Thurs 10:40am, Room 208)
    - Developer Toolset Demos in the Ballroom through the week
    - Further demos in the Developer Lounge through the week

# Contacts

- General questions, thoughts, etc.
  - [rheldevelop@redhat.com](mailto:rheldevelop@redhat.com)
- Red Hat Developer Program
  - Mike Guerette ([mguerett@redhat.com](mailto:mguerett@redhat.com))
  - Langdon White ([langdon@redhat.com](mailto:langdon@redhat.com))
- Red Hat Developer Toolset
  - Product Manager
    - Brian Gollahe ([bgollahe@redhat.com](mailto:bgollahe@redhat.com))
  - Engineering Lead
    - Matt Newsome ([mattn@redhat.com](mailto:mattn@redhat.com), @dev\_tools on Twitter)

**RED HAT®**  
**ENTERPRISE LINUX®**  
DEVELOPERS PROGRAM

## SEE US AT SUMMIT

Visit us at Developer Zone!

## FOLLOW US ON TWITTER

[twitter.com/#!/RHELdevelop](https://twitter.com/#!/RHELdevelop)

## PLAY US ON YOUTUBE

[bit.ly/RHELdevOnYouTube](http://bit.ly/RHELdevOnYouTube)

## LEARN & SHARE AT

[red.ht/rheldevoug](http://red.ht/rheldevoug)

## GIVE US FEEDBACK

[RHELdevelop@redhat.com](mailto:RHELdevelop@redhat.com)



**redhat.**

**RED HAT**  
**SUMMIT**

**LEARN. NETWORK.**  
**EXPERIENCE OPEN SOURCE.**

June 11-14, 2013  
Boston, MA